

ESD Protector Overvoltage Protection Device

Specification Status: Released

BENEFITS

- ESD protection for high frequency applications (HDMI 1.3)
- Smaller form factor for board space savings
- Helps protect electronic circuits against damage from electrostatic discharge (ESD) events
- Assists equipment to pass IEC 61000-4-2, level 4 testing

FEATURES

- 0.15 pF (typ) Capacitance
- Low leakage current
- Low clamping voltage
- Fast response time (<1ns)
- Capable of withstanding numerous ESD strikes
- Compatible with standard reflow installation procedures
- Thick film technology
- Bi-directional protection

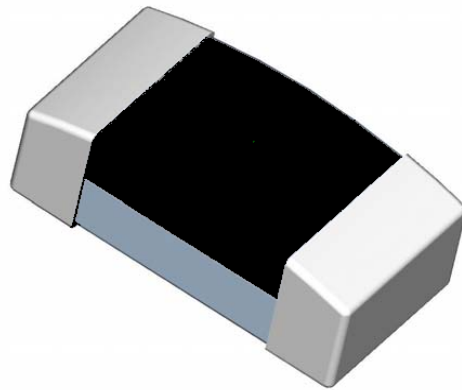

APPLICATIONS

- HDMI 1.3 interface
- LCD, HDTV
- Cellular phones
- Antennas (cell phones, GPS...)
- Portable video devices (PDA, DSC, Bluetooth...)
- Printer ports
- High speed Ethernet
- USB 2.0 and IEEE 1394 interfaces
- DVI interface

CAUTION: This device should not be used in Power Bus applications

TYPICAL DEVICE RATINGS AND CHARACTERISTICS

| Symbol | Continuous Max Operating Voltage | Typical TLP Trigger Voltage ¹ | Typical TLP Clamping Voltage ¹ after 30ns | Typical Capacitance ² @ 1 MHz, 1V _{rms} | Typical Leakage Current @14V _{DC} | Max Leakage Current @14V _{DC} |
|--------|----------------------------------|--|--|---|--|--|
| | V _{DC} | V _{T(TLP)} | V _{C(TLP 30)} | C _p | I _{L(Typ)} | I _{L(MAX)} |
| Unit | V | V | V | pF | μA | μA |
| Value | 42 | 250 | 40 | 0.15 | <0.01 | 10.0 |

Note 1: TLP test method at 1000V (refer to FIG. 5 on page 5)

Note 2: Typical capacitance @ 0V and 14V bias

GENERAL CHARACTERISTICS

Operating temperature: -55°C to +125°C

Storage temperature: -40°C to +85°C

ESD voltage capability (tested per IEC 61000-4-2)

- Contact discharge mode: 8kV (typ), 15kV (max)
- Air discharge mode: 15kV (typ), 25kV (max) [1 pulse: per customer request]

ESD pulse withstand: Typically 100 pulses (tested per IEC 61000-4-2, level 4, and contact method)

Environmental Specifications

| Test Conditions | Bias Humidity Test | Thermal Shock | Bias Heat Test | Bias Low Temp Test | Solderability | Solder Heat | Vibration | Mechanical Shock | Solvent Resistance |
|--------------------|---|--|--|--|----------------------------|--------------|---|--|--|
| | @ 85°C @ 85% RH V _{DC} (max) 1000 hours | -55°C to 125°C 30min dwell 1000 cycles | @ 125°C V _{DC} (max) 1000 hours | @ -55°C V _{DC} (max) 1000 hours | 250°C +/- 5°C 3s +/- 1s | 260°C, 10s | 10 to 50Hz, 60s cycle, 2hrs each in X-Y-Z axis | 1500G, 0.5ms, X-Y-Z axis 3 times | IPA ultrasonic 300s |
| Pass/Fail Criteria | I _L ≤ 10μA | I _L ≤ 10μA | I _L ≤ 10μA | I _L ≤ 10μA | 95% coverage | 90% coverage | No Physical Damage I _L ≤ 10 μA | No Physical Damage I _L ≤ 10 μA | No Physical Damage I _L ≤ 10 μA |

FIG 1: CAPACITANCE VS. FREQUENCY (TYPICAL SAMPLE)

(Flat Response of Capacitance over Frequency Range)

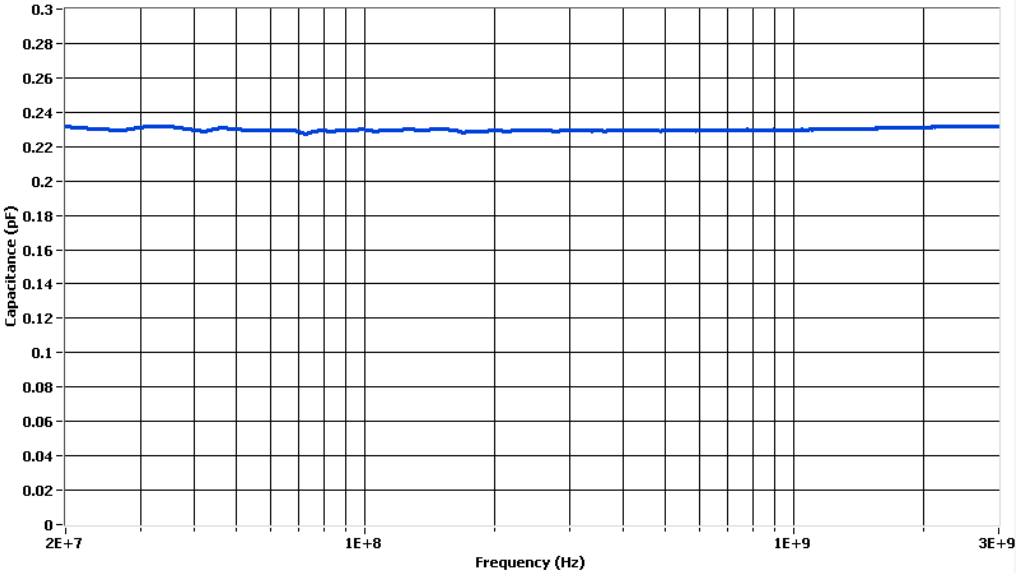

FIG 2: EYE DIAGRAM (TYPICAL SAMPLE)

(Eye Diagram Performance at 3.4 GHz— meets criteria for HDMI 1.3)

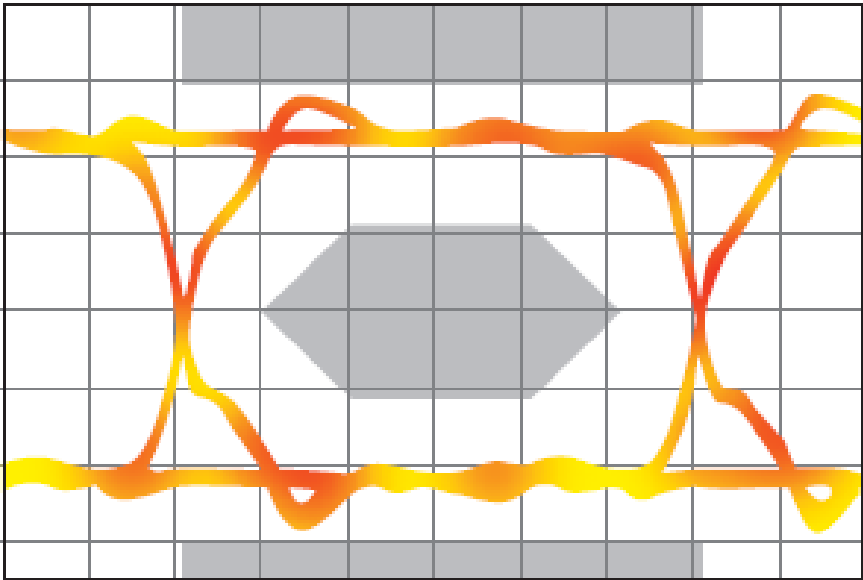

FIG 3: INSERTION LOSS DIAGRAM (TYPICAL SAMPLE)

(Minimal Insertion Loss at 3.4 GHz)

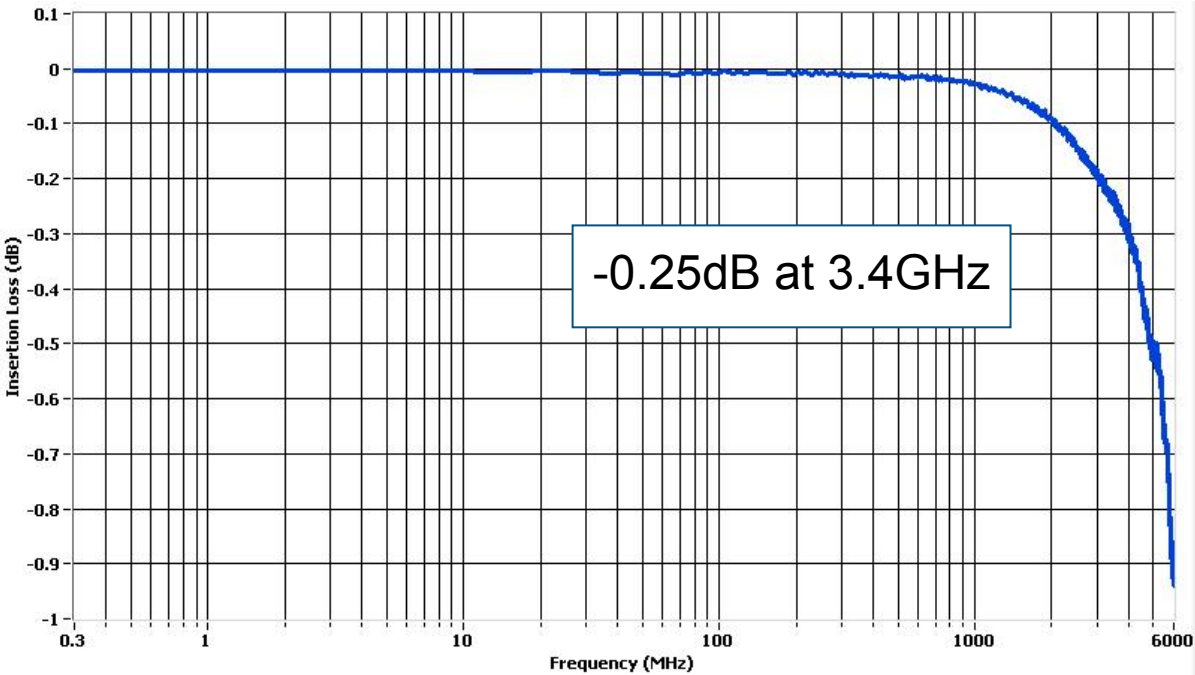

FIG 4: ESD PROTECTION FOR HDMI

(Reference Layout and Test Results available)

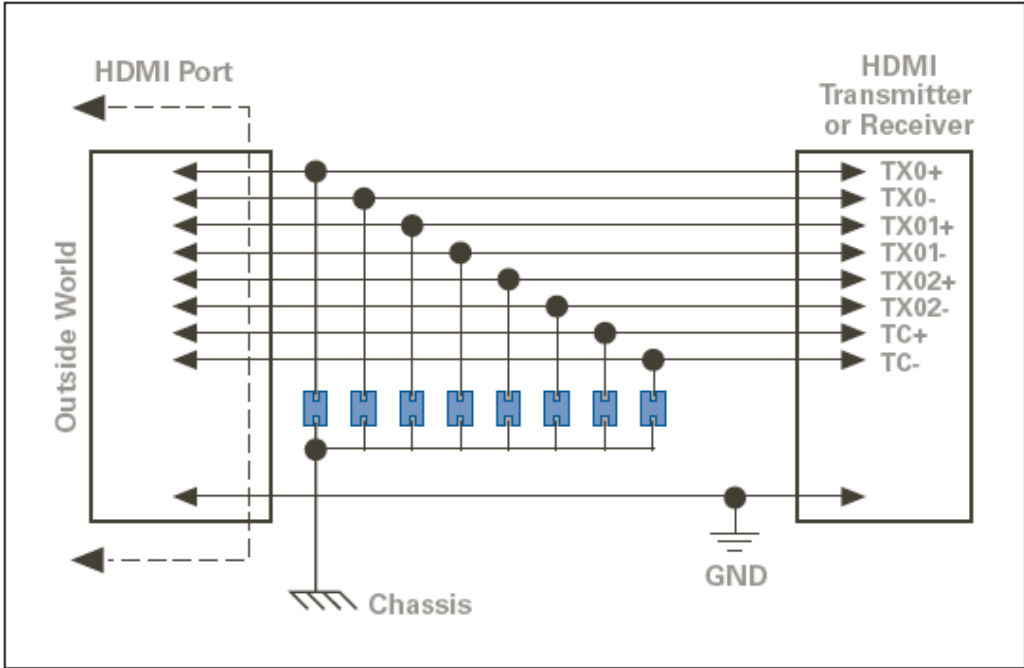
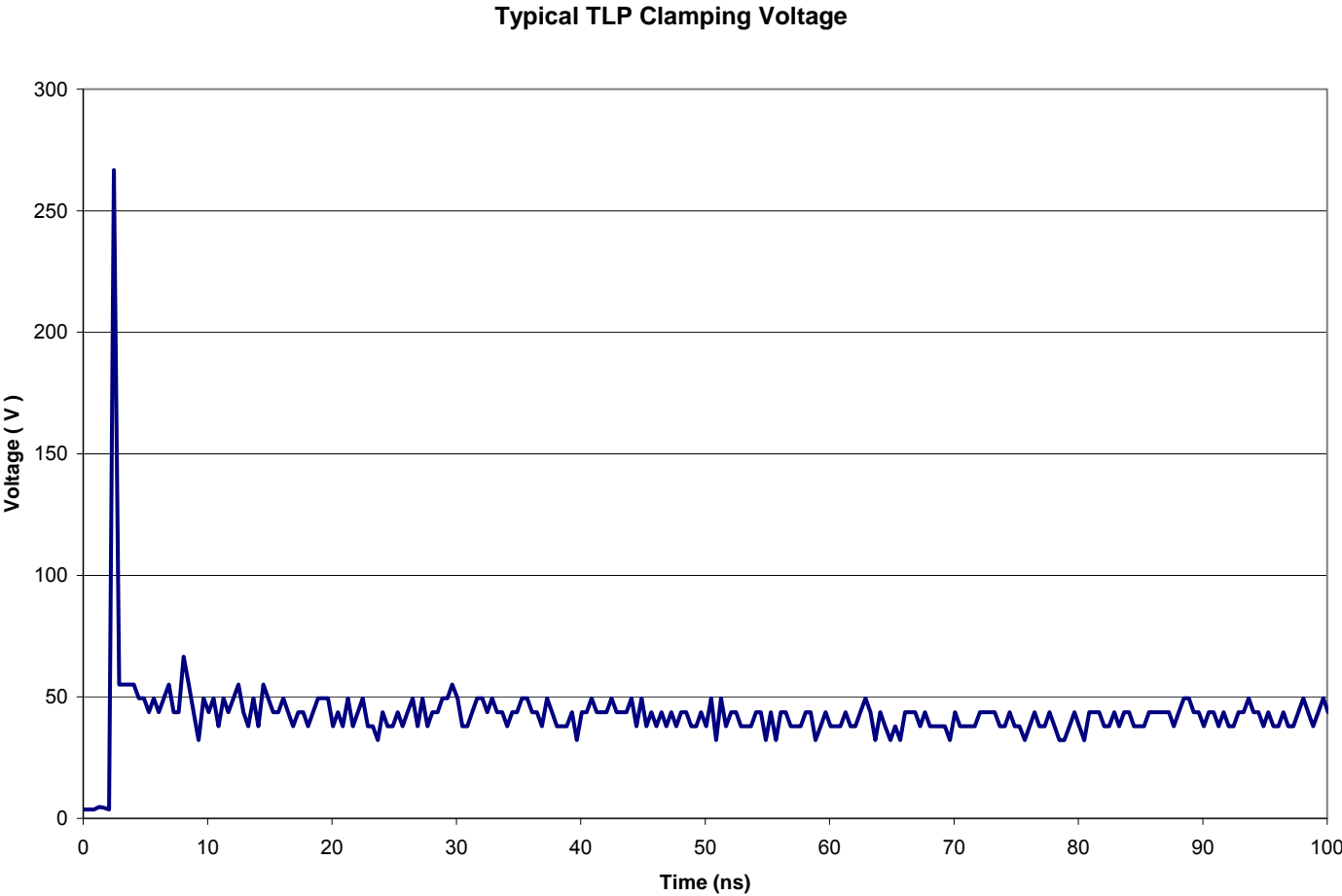
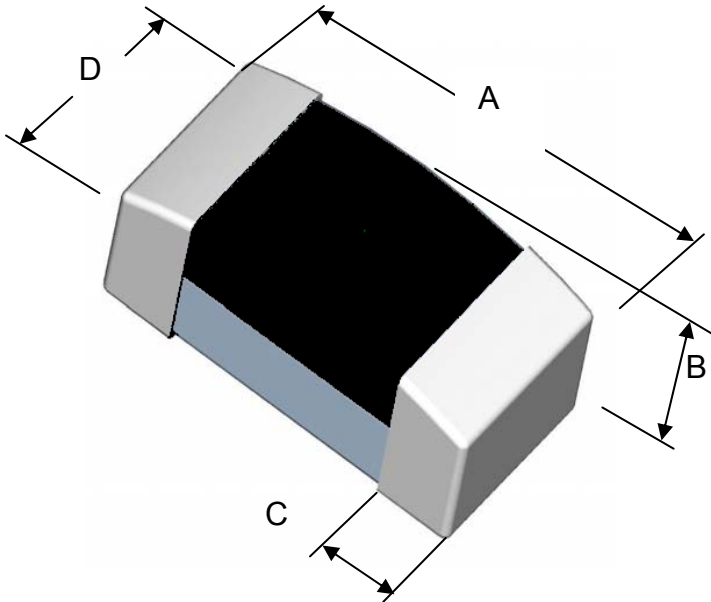

FIG 5: TYPICAL TRANSMISSION LINE PULSE RESPONSE GRAPH



DIMENSIONS



Drawing Not To Scale

| | Length A | | Height B | | Terminal Width C | | Width D | |
|-----|----------|---------|----------|---------|------------------|---------|---------|---------|
| | Min | Max | Min | Max | Min | Max | Min | Max |
| mm | 1.50 | 1.70 | 0.40 | 0.60 | 0.20 | 0.40 | 0.70 | 0.90 |
| in* | (0.059) | (0.067) | (0.016) | (0.024) | (0.008) | (0.016) | (0.027) | (0.035) |

* Round off approximation

RECOMMENDED LAND PATTERN:

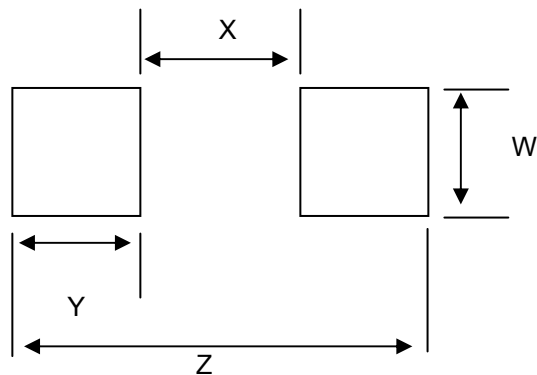

| | W | | X | | Y | | Z | |
|-----|---------|---------|---------|---------|---------|---------|---------|---------|
| | Min | Max | Min | Max | Min | Max | Min | Max |
| mm | 0.90 | 1.00 | 0.50 | 0.60 | 1.00 | 1.10 | 2.70 | 2.80 |
| in* | (0.035) | (0.039) | (0.020) | (0.024) | (0.039) | (0.043) | (0.106) | (0.110) |

* Round off approximation

SOLDER REFLOW RECOMMENDATIONS:

| | | | |
|---|-----------------------|--|---|
| A | Temperature ramp up 1 | From ambient to Preheating temperature | 30s to 60s |
| B | Preheating | 140°C - 160°C | 60s to 120s |
| C | Temperature ramp up 2 | From Preheating to Main heating temperature | 20s to 40s |
| D | Main heating | at 200°C at 220°C at 240°C at 260°C | 60s ~ 70s 50s ~ 60s 30s ~ 40s 5s ~ 10s |
| E | Cooling | From main heating temperature to 100°C | 4°C/s (max) |

